



FENDT

Fendt IDEAL





Fendt IDEAL

- 4 At a glance.
- 6 Spotlights.
- 8 Headers & Feeder house.
- 12 Processor & Cleaning system.
- 18 Residue management & Grain handling.
- 24 Engine.
- 28 Drive, Chassis & Ground drive.
- 32 Cab & Control.
- 36 Fuse & Automation.
- 44 Fendt Services.
- 50 Technical specifications.

At a glance.

Fendt IDEAL. Time for something completely new.

A machine that helps farmers to meet the shortest harvesting windows with uncompromising quality and unconditional reliability. An intelligent technology carrier that lets you experience harvesting in an unprecedented way thanks to state-of-the-art sensor technology and intelligent networking.

- Helix processor
- IDEALbalance™: double shaped return floors.
- Streamer 210 grain tank with up to 17,100 l capacity and 210 l/s discharge rate
- Active Spread straw chopper with hydraulic spreading discs
- AutoDock™: automatic header attachment and detachment in 5 seconds
- Narrow chassis for wide tyres and tracks with best road capability
- Wheel or TrakRide chassis
- ParaLevel version with up to 14 % slope compensation
- DriveCenter: efficient and compact drive
- VisionCab cab for best driving comfort
- IDEALdrive for perfect visibility and an optimised seating position
- IDEALharvest™

Engine		IDEAL 7	IDEAL 8	IDEAL 9	IDEAL 10
Maximum power at 1800 rpm (ECE R 120)	kW/hp	355/483	485/660		
Maximum power at 1850 rpm (ECE R 120)	kW/hp		404/549		581/790



**Fendt IDEAL
 Spotlights.**

Here you will find the special Fendt solutions, the so-called Fendt Spotlights, which make the difference and simply make your work better every day.



2.

4. Helix processor - threshing system and separation

- Longest rotors on the market
- Best grain and straw quality

5. Grain tank

- Up to 17,100 l capacity
- Highest unloading rate on the market with 210 l/s
- Unloading auger available in various lengths up to 9.90 m

6. Straw chopper - ActiveSpread SwingFlow

- The swivelling deflectors optimise straw distribution with continuous swivelling from left to right
- Even distribution across the entire working width in all conditions

7. Dimensions - narrow on the road

- Wide tyre and track offering under 3,30 m, 3,50 m or 3,80 m transport width

1. Headers

- PowerFlow headers with working widths from 7,70 m to 12.22 m
- PowerFlow belts ensure an active and even crop flow

2. Cab

- IDEALdrive: Best in class visibility and control of the cutting unit and intake and a comfortable sitting position
- IDEALharvest: visualisation of crop flow; all important machine parameters at a glance
- New fridge

3. Engine and exhaust system

- MAN/ AGCO Power engines with up to 790 hp
- Airbox - new overpressured and fully encased exhaust system to prevent dust accumulation

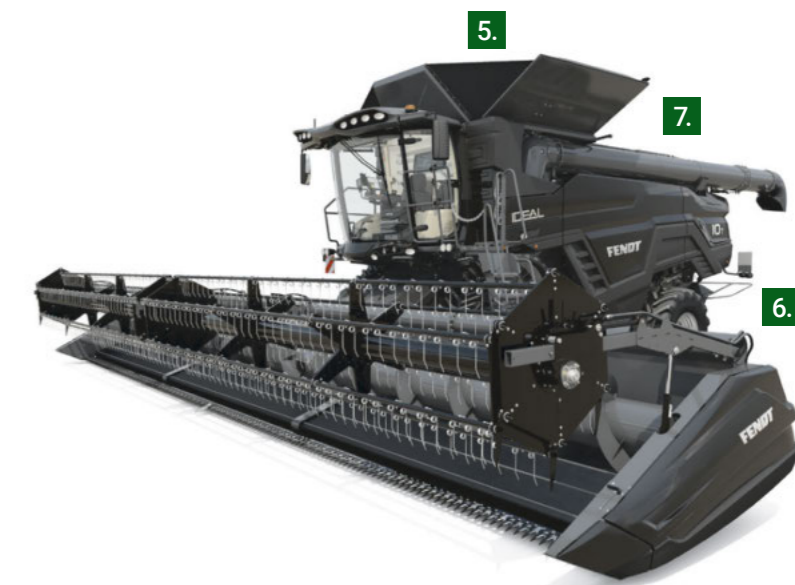

5.

7.

6.



Headers & Feeder house.

Strong from the start – to achieve ideal results, everything has to be right from the start. That's why all Fendt IDEAL combine harvesters work with the latest generation of the world renowned PowerFlow headers.



1. Benefit PowerFlow header

- Optimal head first feed
- PowerFlow belts ensure an active and even crop flow
- SuperFlow auger with 76 cm diameter
- High performance and quality of work in laid crops
- Fast and simple conversion to oilseed rape

- Highest flexibility
- Specific hook up for IDEAL combine
- Headland management for reel position
- Possibility for CTF with 25 ft, 30 ft and 35 ft headers

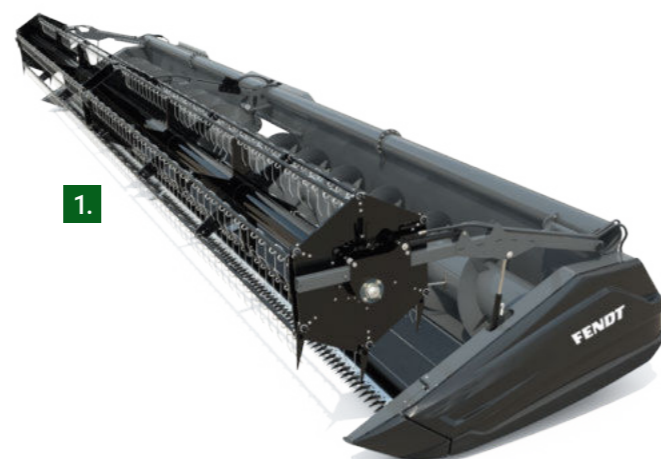

1.

2. TerraControl™ header levelling control

- Fully automatic system, different functions available
- All the levelling functions can work together for an optimal driving comfort and levelling performance
- User friendly system with plenty of possibility of customization
- Many different functions to adapt the system at every working and field conditions
- Precise and reliable
- All TerraControl™ features are standard for all models



2.



3.

3. AutoDock™

- Autodock™ is the latest and most efficient solution in the market to reduce the time spent for the ordinary actions to connect the header
- **Automatic header connection from the cab**
- Hydraulic actuators connect all the functions simultaneously
- **Time to connect – only 5 seconds!**



Customer benefit

- + No need for any help to hook up the header
- + No need to leave the cab
- + No effort to connect the PTO and hydraulic multicoupler



Processor & Cleaning system.

What clearly distinguishes the Fendt IDEAL from other combines is the outstanding single or dual helix processor. The concept of the helix processor combines the required market demands, such as highest throughput, best grain quality and low energy consumption with optimal straw quality.



1. Helix processor with one or two rotors

- **Improves efficiency:** the processor consumes up to 50% less power at an increased straw quality up to 10%
- **Improves simplicity:** the grain loss curve is very flat
- **Improves straw quality:** up to 10% more long straw in the swath than the best competitor
- **Easy to operate:** Requires only the basic speed and concave clearance settings (no additional vanes adjustment or feeder speed adjustment)
- Is **very insensitive** to changing harvesting conditions and keeps the grain loss to a minimum which prevents continuous adjustment by the operator



Customer benefit

- + Low power consumption
- + High straw quality
- + High grain quality



2. Threshing concaves

- Different options of concaves to match all harvesting and crop conditions around the world
- 1. Small wire
 - 9,00 mm spacing (6,00 mm between wires)
 - Grain & cereals such as canola/rape
- 2. High Capacity Small wire
 - 13,50 mm spacing (9,50 mm between wires)
 - High yield cereals and peas & beans mix
- 3. Large wire - 25,50 mm spacing
 - Corn and soy-beans
- 4. Round bar
 - Dry corn or delicate corn varieties
- High flexibility: it is possible to install different combination of concaves
- No need of mechanical adjustment after concave replacement.
- Easy change of the concaves through the lateral inspection doors without the need of removal of other components

3. Finger grates

- Base configuration for Small Grain version
- Each independent finger has an opened design.
- The fingers are mounted with an offset, one from each other, which prevents any plugging of the grates
- The finger grates design offer a smooth surface for the straw-flow
- This finger shape design is one of the reason for outstanding straw quality and low power consumption of the processor. The less resistance to the crop flow, the better the straw quality and the lower the power consumption.

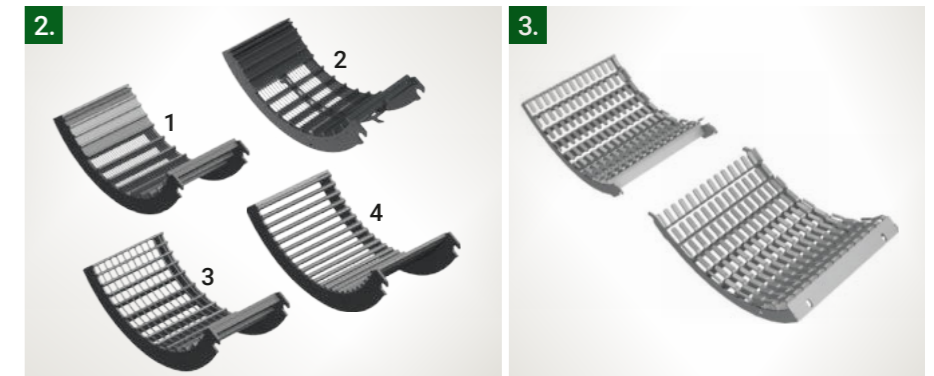
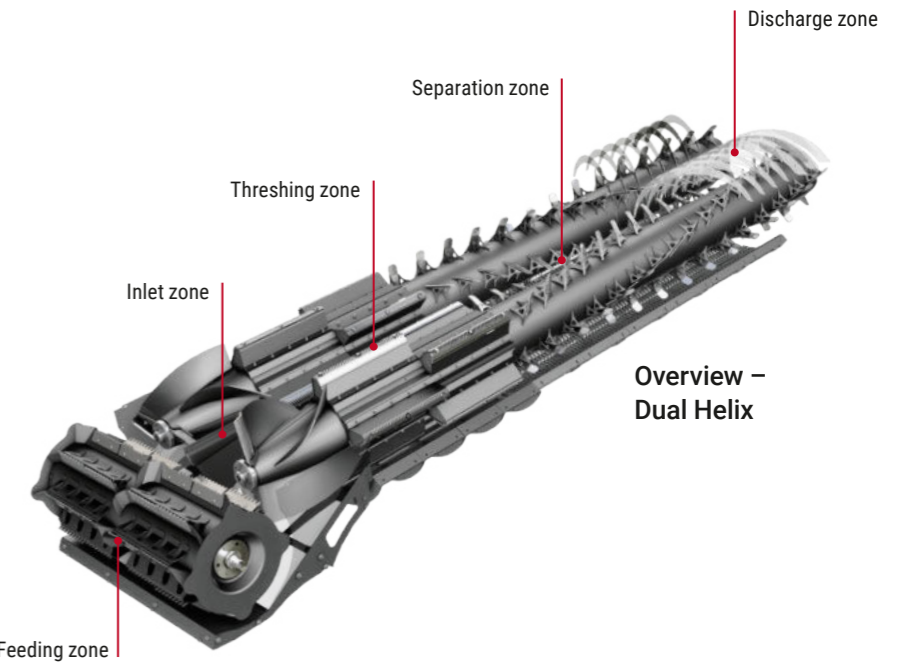

Customer benefit

- + Low power consumption
- + High straw quality
- + High separation capacity



1. IDEALbalance™

- IDEALbalance™ is a unique and patented system composed by two curved return pans:
- The front pan collects the material from the threshing zone of the rotors and delivers the material to the grain pan at the very front
- This allows to use the entire length of the preparation pan
- The rear return-pan collects the material from the separation area of the rotor and feeds the grain pan on the sides

- Technical advantage:
- The grain pan is fully loaded from the front and uses its full length to prepare and stratify the material before the cleaning shoe
- Stratified material with heavy grain at the bottom of the layer and light material/chaff on top.
- Each section of the grain pan is equally charged in all conditions



1.

2. Slope compensation

- The curved shape of the two return pans, provide a passive slope compensation up to 15 % transversal slope
- The even feeding of the preparation pan is independent from:
 - Slope
 - Crop conditions
 - Machine feeding
- Optimal stratification of the material before the cleaning system
- Simplifies the activity of the cleaning system
- Maximizes the performance of the cleaning system



Customer benefit

- + Reduces cleaning shoe grain loss about 60 % while harvesting on side hills at 15 %
- + Simple and efficient, no moving parts, no adjustments required

3. The longest sieve-box in the market

- IDEAL 9-10: 2.20 m long chaffer/top sieve – 4 channels
- IDEAL 7-8: 2.00 m long chaffer/top sieve – 4 channels
- Two different sieve-box dimensions to match the machine capacity
- Narrow sieve-box width of 1.40 m, easy to pressurize
- Electrical adjustable top and bottom sieve as standard
- Sieve extension offset can be set-up manually and will move together with top-sieve adjustment
- Tall dividers support the slope compensation capability up to 15 %
- Corn design top and bottom sieves available with corn configuration



2.

15 %



3.



Residue management & Grain handling.

A grain tank volume that is second to none! With the large grain tank and the enormous unloading rate, you are on the safe side. The fewer stops, the quicker the valuable crop is in the dry.



1. Three different spreading direction

- 1. **Chop and mix:** chaff in the straw chopper
 - The chaff is conveyed into the chopper and spread together with the chopped straw
 - Chaff spread on the full cutting width
- 2. **Drop and mix:** chaff into the straw-swath
 - The chaff spreader is slowed down and the chaff is mixed in the straw swath
 - Maximizes the straw quantity and quality
 - Excellent straw for animal feeding
- 3. **Divide:** chaff on the sides
 - Deflectors are directed on the sides and the chaff is spread separately from the chopped or swathed straw

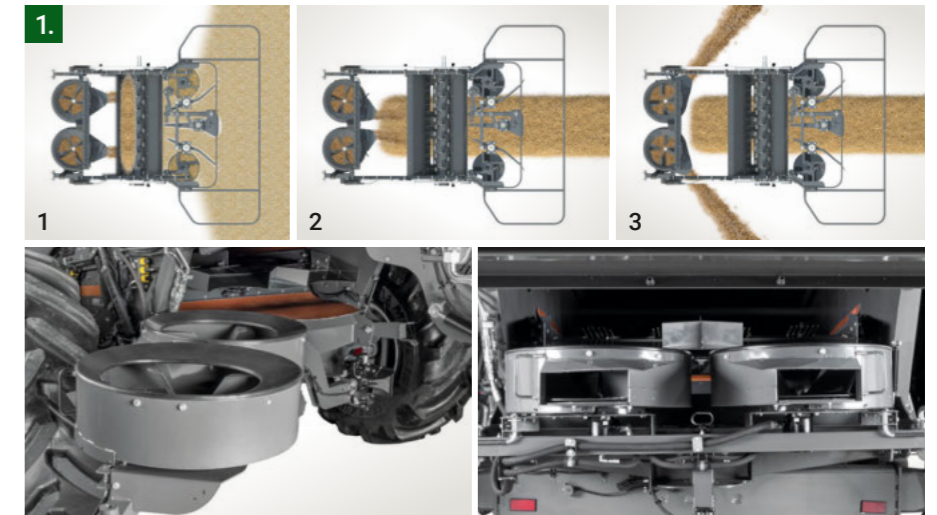

Residue Management

- Chaff spreader is mounted in **horizontal position**
- Two hydraulically driven discs with **variable speed adjustment**
- Three Different spreading directions
 - Chop and mix: chaff in the straw chopper
 - Drop and mix: chaff into the straw-swath
 - Divide: chaff on the sides
- Spreading deflectors:
 - Manual adjustment (in base for all models)
 - Electric adjustment from the cab as option
- Easy to swing away the spreader for access to the sieves
- Can be easily removed if not required in some crop
- Speed and blockage sensor on RHS



Customer benefit

- + Flexible handling of the chaff
- + Spreads on full width: facilitate the following cultivation
- + Maximize the straw quantity and quality for baling

AutoSpread

- The spreading width will automatically adjust in function of the coverage map of the Section Control
- Combine needs to be equipped with guidance
- Function available with:
 - Passive electric deflectors
 - ActiveSpread
 - ActiveSpread SwingFlow
- Uniform distribution of the residues

2. ActiveSpread SwingFlow

- Two hydraulic spinners with three swinging deflectors, hydraulically driven
- Retains the small diameter spinners geometry from the ActiveSpread for a low power absorption
- The swinging deflectors optimize the residue distribution with a continuous swing left to right
- Inlet and outlet of the tailboard have a continuous swinging movement to create a homogeneous spreading pattern
- Recommended for headers 30 to 40 ft



Customer benefit

- + Homogeneous spreading pattern in all crops and conditions
- + Very low power requirement
- + Easy adjustment from the cab





1.

Streamer 140

- Unloading rate 140 l/s
- 12.500 l grain tank
- Unloading time: 90 sec
- Standard for ParaLevel models
- Short transmission chain, reduced noise and wear
- Low transmission speed: 550 rpm
- Big diameter of the auger: 350 mm
 - Prevents broken grain during unloading
- Single cross auger at the bottom of the grain tank

1. Streamer 210 – the fastest unloader in the market

- Unloading rate 210 l/s
- 17.100 l grain tank
- Unloads the 17.100 litres grain tank in **81 seconds!**
- Big diameter of the unloading auger allows the system to spin at very low rpm:
 - Grain travels only at 3 m/s
 - Prevents broken grain
- Very low power required thanks to a dedicated geometry of augers and transmission.
- **210 l/s unloading rate at the same power consumption per 100 l/s of a 6 straw walker combine**
- Double cross auger at the bottom of the grain tank



Customer benefit

- + Less time for unloading: reduces time and distance the cart has to follow the combine
- + High unloading rate at a low power consumption

2. Hydraulic adjustable unloading rate

- Adjustable unloading rate controlled from the MFL
- Adjusts the grain flow to the unloading auger
- An hydraulic actuator moves the plates on top of the cross-augers, in five positions:
 - Close < (0 %, 25 %, 50 %, 75 % and 100 %) > Fully opened
- The unloading gates can move up and down even when the grain tank is full:
 - The gates close automatically when the unloader is **disengaged**
 - The gates **open** automatically to the set-point when the unloader is **engaged**
- Allows to optimize the unloading speed in each crop and condition

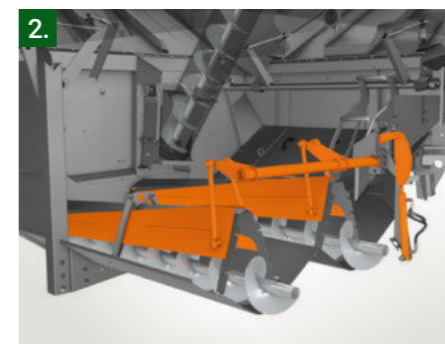

2.

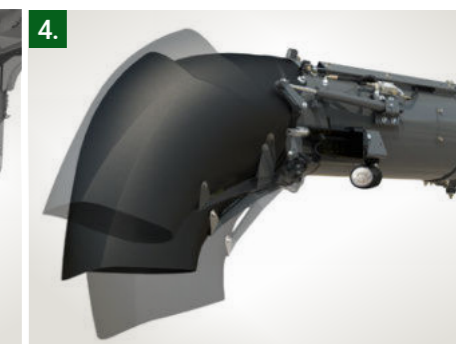

4.

4. Adjustable Spout

- Electrical adjustment of the spout movement
- 40° excursion of the spout
- Adjustment **controlled from the MFL**
- Available for all IDEAL models
- Available for both STREAMER 140 & 210

3. Unloading auger offering

- Different unloading auger lengths available
- Avoids running the trailer on the swath while unloading
- Leaves the swath in a good shape for baling
- The right auger for the right header
- Foldable auger for the 8,4 m and 9,9 m lengths
 - Electrical actuator for the folding mechanism
 - 1.5 m unloading auger extension folds 131°
- Maintains an agile dimension on the road

S 7.0 unloading auger and 25 ft header



3.

M 8.4 unloading auger and 30 ft header



3.

L 9.9 unloading auger and 35 ft header

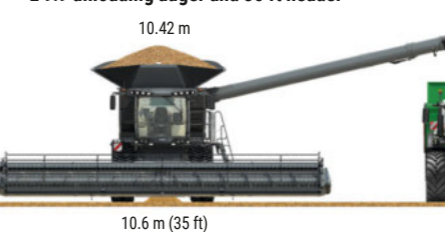

3.



Customer benefit

- + Tractor and grain cart can drive over swath which leaves the swath in a good shape for baling
- + Controlled traffic farming is possible with a lot of header/unloader combinations



Engine.

Moving forward and going far has never been easier. In order to form the best overall package in each case, four different engines also operate in the four Fendt IDEAL models, which are perfectly adapted to the possible output of the IDEAL 7, 8, 9 and 10. Maximum fuel efficiency can only be achieved with an engine that is perfectly matched to the possible output.



IDEAL 7 engine

- The AGCO Power engine, 7 cylinder and displacement of 9.8 l, is the most used engine in the high range horse power agricultural machines of AGCO: combines and tracked tractors
- The engine has 4 valves per cylinder
- Common rail injection technology
- Twin stage turbo and intercooler aspiration system.
- Meets the Stage 5 regulation with EGR, SCR, DOC and DPF
- Hinged exhaust covers for serviceability

IDEAL 8 engine

- The MAN engine model D2676, is an in-line 6 cylinder diesel with a displacement of 12.4 L
- Same engine as of the 1000 Vario tractor range
- Common rail fuel injection 2500 bar
- 4 valves per cylinder
- Turbocharger with intercooler
- Meets Stage 5 regulation with EGR, SCR, DOC and DPF
- New design, compact size: good compromise between weight and performance
- New AirBox (over pressurized exhaust box) to avoid critical dust accumulations

IDEAL 9 engine

- The MAN engine model D3876, is an in-line 6 cylinder diesel with a displacement of 15.2 L
- Common rail fuel injection 2500 bar
- 4 valves per cylinder.
- Turbocharger with intercooler
- Meets Stage 5 regulation the with EGR, SCR, DOC and DPF
- New design, compact size: good compromise between weight and performance
- New AirBox (over pressurized exhaust box) to avoid critical dust deposits

2. IDEAL 10T engine

- MAN D42 – 16.2 L – 6 cylinders
- Stage V compliant with SCR and EGR technology
- Max Power 790 hp (ECE R120)
- No need of DOC and DPF to meet Stage V regulation
- Common rail technology
- The most powerful inline six-cylinder engine for agricultural machines that MAN engines has ever developed
- The highest power-to-weight ratio in its displacement class
- New AirBox (over pressurized exhaust box) to avoid critical dust accumulations

3. Air compressor – Option

- Compressor flanged directly to the engine
- Single compression cylinder
- Outlet pressure up to 9.5 bar
- The air compressor supplies 600 l/min @1000kPa.
- Air tank capacity of 60 l
- 2 air plugs around the machine to plug the 10 m extension hose
 - Under cab platform
 - On the RHS in the rear, close to service ladder



Customer benefit

- + No need for daily cleaning action
- + Enlarge the life cycle of the engine air filter
- + The engine performance always at the maximum air intake

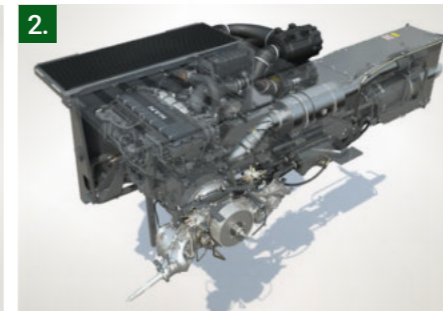
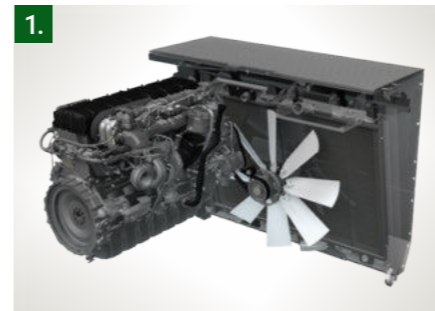

1. AirSense® cooling – Self cleaning

- Reversible Fan with 8 blades diameter 950 mm
- Possible to invert the air flow direction, from sucking air to blowing air, to clean the radiator surface and the intake screen on top
- The airflow is inverted by changing angle (pitch) to the paddles of the fan
- The dust and chaff blows away
- Engagement depends on temperature and time.
- Manual engagement possible
- No rotary dust screen required
- One harvest season without manual cleaning the radiator!
- Total ventilated surface 2.7 m²



Customer benefit

- + Easy maintenance and cleaning
- + 50 seconds of air reverse with engine off

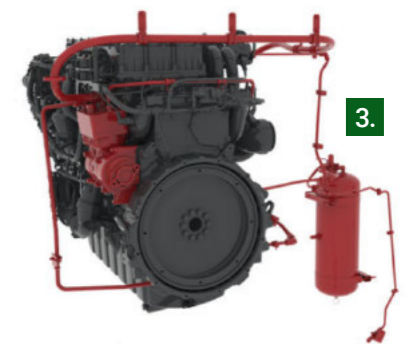



Drive, Chassis & Ground drive.

With the Fendt IDEAL, you're equipped for every application. The ground drive of the Fendt IDEAL consists of proven transmission technology combined with the latest hydrostatic ground drive technologies. In addition to comfortable and efficient progress, reliability is the absolute strength.



1. One power unit – everything connected

- A unique gearbox, directly flanged to the engine drives all the main drivelines of the machine: processor, cleaning, header, hydraulic pumps
- **High efficiency** transmission of the power to the main drives
- DriveCenter has a **self lubrication system**
- Electro-hydraulic clutches ensure an **smooth engagement** of processor, cleaning and header
- **Alloy housing** to reduce overall weight
- **DriveCenter has its own oil-bath** which can be monitored easily from the ground by two glasses to check the oil level
- Very efficient transmission with a very low amount of belts



Customer benefit

- + Straightforward power transmission
- + Simplicity and easy maintenance
- + Reduced fuel consumption

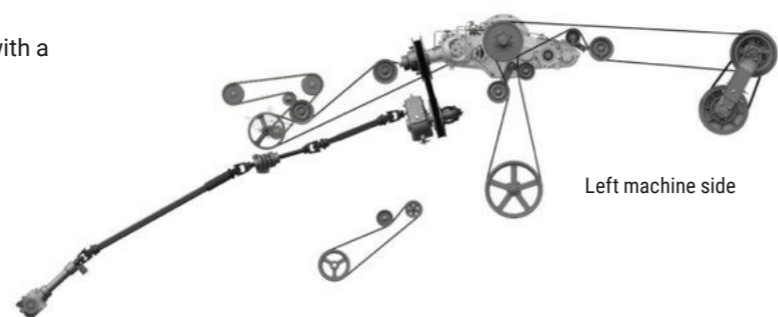
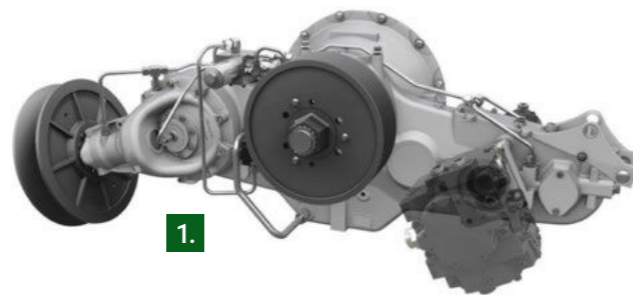

2. Features ground drive

- TrakRide rubber tracks system
- Large tires at only 3.3 m transport width
- Differential lock in standard
- **MotionShift 2** speed gearbox up to 40 kph
- 3 different driving modes
- **AllDrive** automatic 4wd engagement
- Efficient hydraulic circuit
- Impressive steering angle
- **ParaLevel** front axles up to 14 % slope compensation

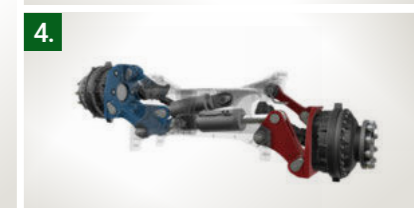

3. Three different sizes, hydraulically suspended

- Triangle rubber track system with three different belt sizes: 26', 30' and 36'.
- Suspension system with belt tensioning integrated
- Rollers and wheels with bearings in oil bath
- Belt tensioning monitored in the combine terminal
- **Oil bath** bearings sealed with a patent ring
- **Service windows** to check oil level
- Built by the **AGCO specialist for tracks in Jackson (US)**
- Up to 60% same components with AGCO track tractors

4. ParaLevel front axle

- 14% slope transversal levelling
- Available for IDEAL 7-8-9, only with **STREAMER 140** grain handling system
- Can fit the following tires:
 - 800/70R38 < 3,5 m
 - 900/60R38 < 3,8 m
- Final drives are fitted to a solid parallelogram structure
- Smooth levelling controlled with proportional hydraulic valves
- Keeps the full machine levelled when working in slopes, completely automatically
- Buttons on the armrest for manual control
- Safety is improved as large and heavy combines with big grain tanks working on slopes without a levelling system have a severe risk of overturning.



Customer benefit

- + Maximized foot print and reduced soil compaction
- + Wide contact area, narrow transport width
- + High driving comfort on the road and in field



Cab & Control.

The IDEAL workplace for you. The Fendt IDEAL offers a cab with top comfort and the best possible view of the headers and all functions, making harvesting a walk in the park.

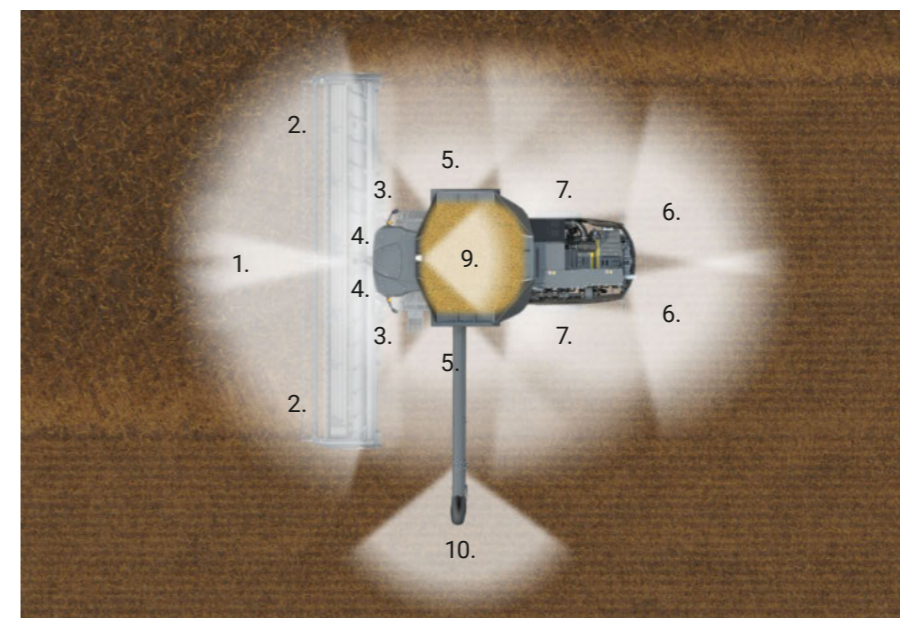

Working light

- 1. 2 LED long range lights
- 2. 6 LED short range lights
- 3. 2 halogen stubble lights
- 4. 2 LED front valance lights
- 5. 2 halogen row finder lights
- 6. 2 halogen rear working lights
- 7. 2 halogen rear axle lights (option)
- 8. 1 halogen light in the engine bay
- 9. 1 LED light on the grain tank
- 10. 1 halogen light on the unloading tube

Comfort

- Vision cab has been developed to ensure the best front visibility to the header
- Glass surface of 5.75 m²
- Full 180° range visibility
- Very thin pillars
- Front sun-visor as standard
- New ergonomic design
- Steering column can be adjusted in 3 directions
- Wide wiping area of the wind-screen
- Operator comfort is further improved
- Foot-rests for a more comfortable legs position
- Very comfortable and large room also for the passenger

IDEALdrive - a new driving experience

- The standard steering-wheel is replaced by a joystick, located on the left side armrest of the driving seat.
- The steering column is completely removed
- Unprecedented visibility and control over the header.
- Increased relax for the operator: university studies confirm that this system reduces the muscle activity of the 65 %.
- Available for TrackRide versions only
- Homologated for EU road circulation requirements by TÜV
- Follows ISO-25119 Functional Safety Standard

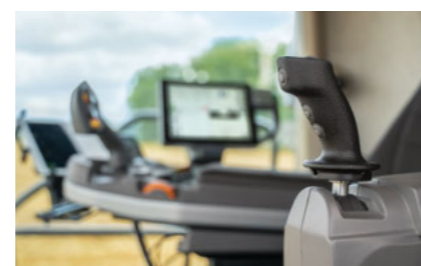

Customer benefit

- + Operator comfort
- + Great habitability room, ergonomic positioning of all controls
- + Super visibility through a massive glass area

Key features & specification

- Intuitive and ergonomic layout of the controls
- Pulse motion multifunction lever
- Innovative control of the unloading auger with the scroll wheel
- Terminal 10.4" screen with large possibility of customization
- Additional dashboard keeps all the important information always under eye-control
- SmartConnect™ app wi-fi connectivity as standard
- The iPad can be used as additional screen (not included)

- Different Cruise modes as standard
- Telemetry with 5-years license included as standard
- IDEALharvest™ - Visualization as option for a unique in the market visualization of the crop-flow in the machine



Customer benefit

- + Intuitive and comfortable controls
- + Easy to use
- + Increase the operator's productivity from day-one





Fuse & Automation.

Do you want a relaxing harvest? Not a problem! Whether it's track guidance, the optimal overview of all machine settings or the documentation of data. The Fendt IDEAL offers ideal solutions for a relaxing harvest.



1. Novatel SMART 7

- Compatible with all GNSS systems: Multi-constellation and Multi-frequency antenna
- Simultaneously track up to 3 TerraStar satellites
- Upgrade to RTK:
 - RTK via NTRIP (cellphone network)
 - RTK via Radio base station
- New accuracy levels available with TerraStar-C PRO
 - Precision: 2 cm, with initialization time < 18 minutes
 - Provides Centimeter accuracy with decimeter level unlock
 - Centimeter accuracy available even for regions with no RTK coverage
- No need of additional parts to upgrade the accuracy of the receiver

2. Trimble AG 382

- Extremely efficient receiver with even more options
- Supports EGNOS / WAAS and Rangepoint RTX in the Standard version
- Rangepoint RTX free of charge for the first year
- Centerpoint RTX and Centerpoint RTX fast optional available
- Upgrade to RTK without any problem:
 - RTK via NTRIP (Cellphone)
 - RTK via Radio base station
 - RTK via stationary Trimble Network (radio)
- In case of RTK breakdown up to 20 minutes bridging (Trimble xFill-Technology)



3. Automatic cutting width control - easy and more precise

- Requires a Guidance antenna to be installed
- Standard feature, no additional hardware required
- Uses the guidance signal to determine the harvested area
- In case of overlap, the system reduces automatically the cutting width of the header, used for the hectare counters
- This creates a very precise coverage map and yield calculation

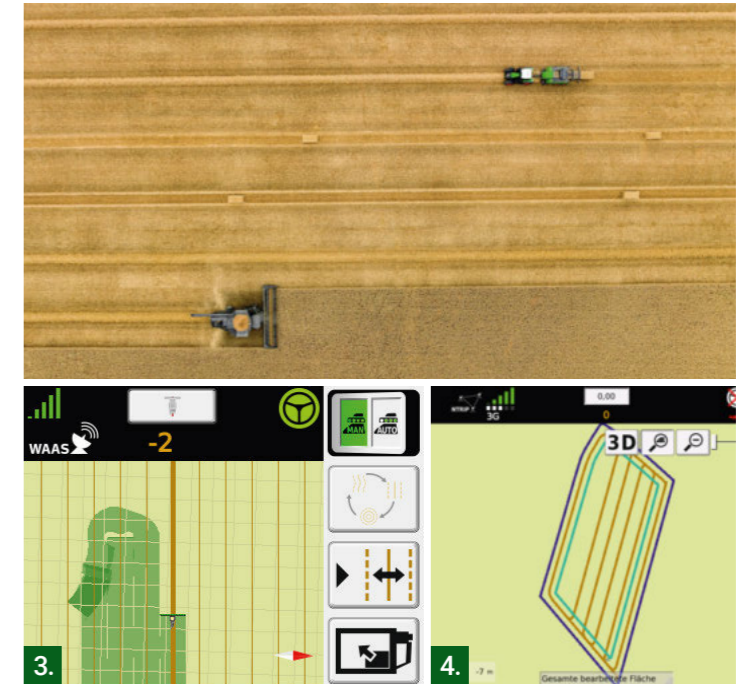

Customer benefit

- + Completely automatic header width control
- + Accurate recording of the real harvesting area
- + Very precise yield and performance data recorded

4. Contour assistant package

- The feature Contur Assistant Package will be part of the Guidance package when ordering:
 - Guidance Standard Novatel or RTK
 - Guidance Standard Trimble or RTK
- One unique guidance package will contain all the guidance features
 - Contour segments
 - Single contour
- Contour Segments is an additional way-line type that simplifies the creation of way-lines
- While driving around the field the operator is able to record different segments within one way-line
- From the Contour Segments you can easily create a field boundary
- The Single Contour way-line mode enables the recording of one track with free contour



Customer benefit

- + Simple management and creation of new boundaries and waylines

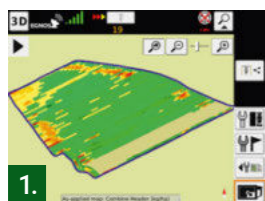

1. The right conclusion in real time

- Live yield mapping provides a real time view of the harvested yield directly in the terminal.
- The live mapping view shows the different productivity within a field in the current defined GPS position.
- The operator sets the task data in the terminal and starts to harvest
- Different layers such as harvested area, yield and moisture can be displayed
- The function requires GPS data input from the Guidance antenna



Customer benefit

- + The operator can easily have an overview about the crop yield and identify poor yielding areas of a field in real time
- + Fully integrated into the combine terminal



Customer benefit

- + Relief of the driver at the headland
- + Perfect positioning line for line

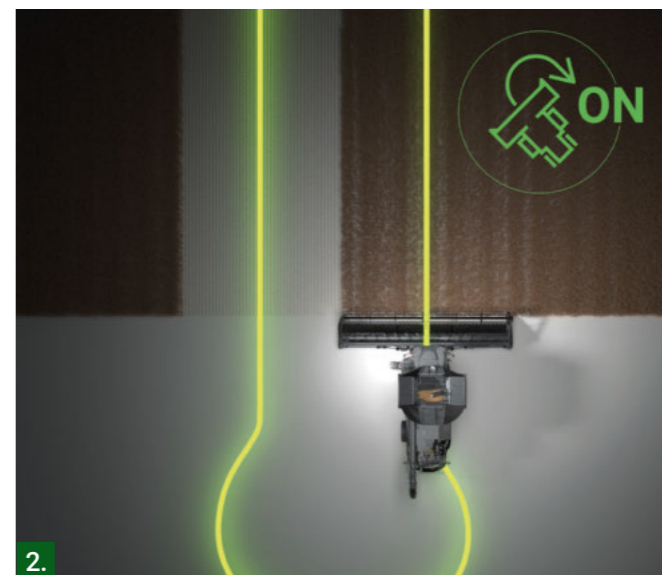

2.



2. TI Turn Assistant

- Automatic turning process on the headland
- This feature entitles the operator to run the turning & the headland management including the steering in an automated way by just pressing the activation for the headland turn

Connect telemetry with 5-years license

- Fendt Connect is a fleet management telemetry system that collects data relating to machine location, settings and performance
- Allows the owner to get live information from the field through web access
- ACM control unit factory fitted (Telemetry ready), sends data via mobile network or satellite to the cloud-based FUSE platform, the General Purpose Platform (GPP)
- Data is visualized via the AGCO Connect website and app
- **Fendt Connect 5-years license included**
- All IDEAL combines are ready to be registered, free of charge, within 18 months from production
- The website allows the collected data to be viewed in real time or analyzed at a later date
- Allows User to improve efficiency
- Allows User to increase profit margins by managing vehicle performance
- Connect Telemetry activation is required to be able to use the option **Combine to Combine machine communication**
- Find out more about Connect telemetry at: <https://get.agcoconnect.com/>



1. Real time crop visualization

- Mass acoustic sensors along the rotor (s) and cleaning show allow to detect the crop mass flow along the combine to identify:
 - Load distribution front to rear
 - Load distribution left and right
- **Real Time**, easy and intuitive identification of the crop distribution inside the combine
- **Grain distribution** – the load curves clearly display to the operator where the grain separation happens, allowing for a better fine tuning of the combine’s adjustments. They also help to determine partial clogging of concaves or sieves without the need to stop the machine, as well as uneven feeding.



Detailed view of the Crop Load: the operator has a left/right view from the rear of the combine. Moving the slider along the length of the processor, it is possible to visualize the crop load in each area.

HarvestPlus – harvest modes

- **Constant speed**
 - Possibility to operate at two different constant harvesting speeds C1 and C2
- **Constant feeder load**
 - Monitors the feeder load and adjust the ground speed accordingly
- **Constant feeder load and performance**
 - Monitors the rotor and cleaning shoe losses combined with feeder load
- Engine load is always monitored in the background



Customer benefit

- + Easy machine operation
- + Constant load of the machine
- + Increases throughput over a day up to 15 %



IDEALharvest™

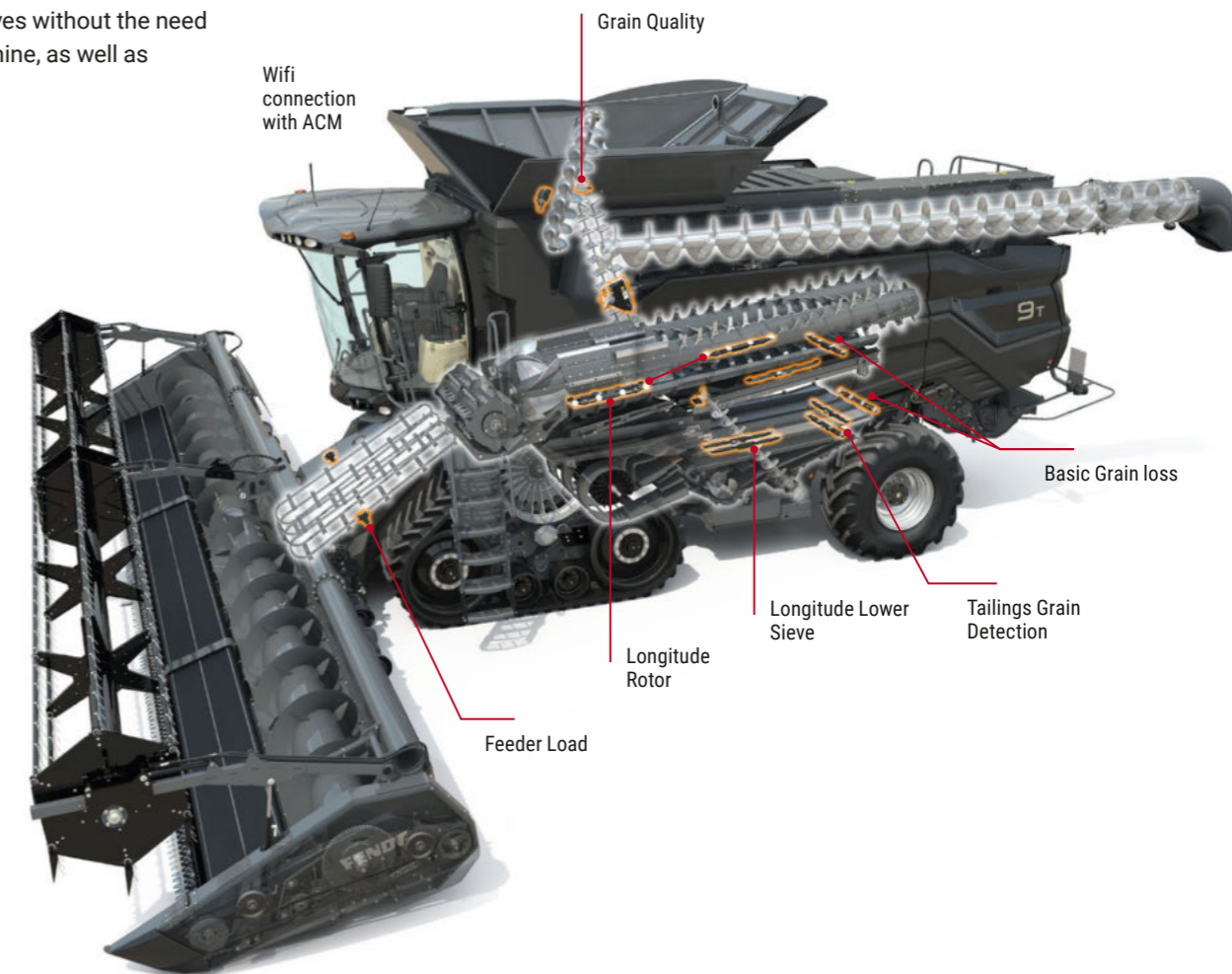



Fendt Services.

A Fendt machine is a high-tech product for the highest of demands. Accordingly, the certified Fendt sales partners offer first-class service.



+44 330 123 9909

You can contact the certified service partners around the clock via the Fendt Customer Hotline



The best product under the best protective shield

- Extraordinary service partners and service:
- A short distance between our trained service employees and you
 - 24/7 Replacement parts availability during the season
 - 12 month guarantee on Fendt original parts and installation

100 % quality. 100 % Service: Fendt Services

- Fendt Demonstration Service
- Fendt Expert Driver Training
- AGCO Finance – Financing and Leasing Offers
- Fendt Care – Service contracts and warranty extension
- Fendt Certified – Used machine programme

Ensure the operation of tomorrow today.

- Fendt Demonstration Service**
- Get on and try it out, instead of just talking about it
 - Basis for an optimal decision-making process

- Fendt Expert Driver Training**
- Exclusive practical training with professional trainers
 - Optimization of efficiency by learning all of the functions and exploiting the entire performance potential of the Fendt machine

- Individual financing and leasing models**
- Credit financing by AGCO Finance with attractive conditions, flexible terms and projectable costs
 - Tailored leasing offers via the Fendt sales partner



- Fendt Care – Service contracts and warranty extension**
- Tailored maintenance and repair service that goes beyond the warranty
 - Maximum safety of use
 - Flexible terms and rates with and without deductible
 - Full cost control and planning security
 - Only original parts used with guaranteed production quality and tested for reliability for maximum value retention of the Fendt machine

- Fendt Certified* – Used machine programme**
- Used agricultural machines with proven high-quality and certified Fendt quality
- Advantages:**
- Certification according to demanding quality standards
 - Extensive initial check (technology, wear, appearance)
 - Meticulous maintenance of wearing parts
 - replacement, cleaning and painting of components as needed
 - Includes warranty

*Fendt Certified only available in GB/FR



Fendt Care.

Cost control and planning security with the Fendt Care rates

- Comprehensive range of services to ensure operational safety and repairs on new machines
- Full cost control with the best service
- Tailored solution for the fleet from maintenance contract to complete worry-free package including replacement machine

Smartphone-App "AGCO Parts Books to go"

- Find replacement parts quickly and order directly
- Download via the App Store or the Google Play Store
- Access data via the Fendt sales partner

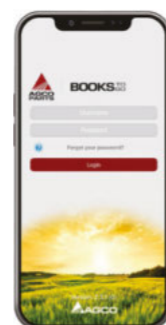







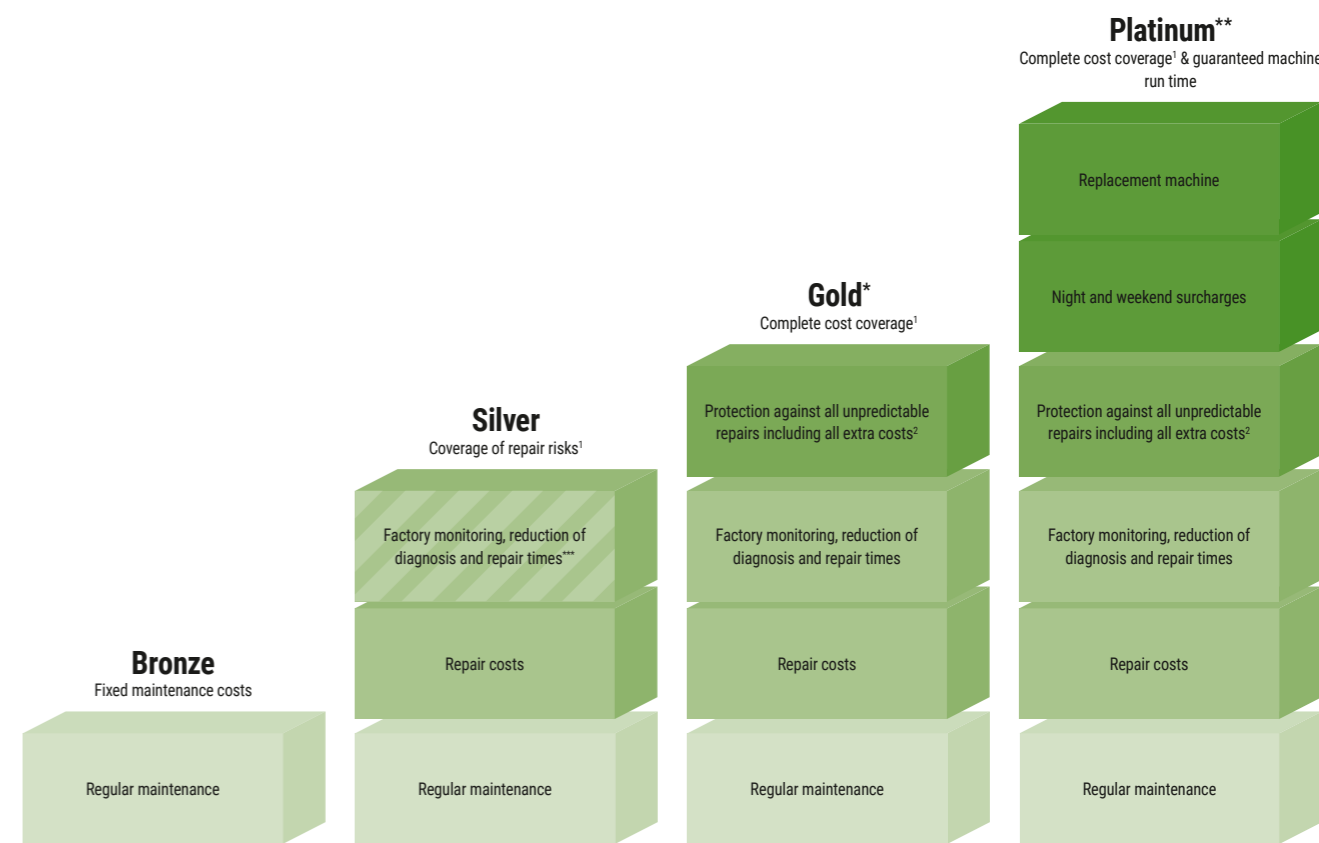



App Store



Google Play Store



	Complete Fendt Portfolio	Complete Fendt Portfolio	Wheeled tractor with Fendt Connect & telescopic loader ⁸	Wheeled tractor with Fendt Connect
Available for	Complete Fendt Portfolio	Complete Fendt Portfolio	Wheeled tractor with Fendt Connect & telescopic loader ⁸	Wheeled tractor with Fendt Connect
Customer benefit (deductible)	Operation safety of the machine	Coverage of large-scale damage ³ (490 €) Comprehensive coverage at attractive rates (190 €) Complete coverage with full cost control (0 €)	Complete coverage with full cost control including all extra costs (0 €)	Complete coverage with full cost control including all extra costs & guaranteed machine run time (0 €)
Maximum coverage Warranty extension	 8 Years / 8,000 OH	 5 Years / 3,000 OH	 5 Years / 5,000 OH	 3 years / 2,000 OH ⁴
		 3 years / 4,000 OH ⁵	 3 years / 25,000 bales ⁶	 5 Years / 50,000 Bales
		 8 Years / 4,000 pump-H	 5 Years / 8,000 OH	 5 years / 750 OH ⁷

OH = operating hours; H = hours; ¹ excluding wear and tear; ² travel costs, recovery / towing, troubleshooting with additional diagnostic tools, use of dynamometer, oils and filters if engine / transmission is repaired; ³ only available for machines with self-propelled & RG300 & Momentum; ⁴ ISOBUS-enabled machines only; ⁵ PR, VR & XR only; ⁶ incl. Rollcutter; ⁷ Momentum 16 & 24 only; ⁸ Gold rate for telehandler also available without Connect; ⁹ Gold rate only available in DE, FR, GB, IT, BG, CZ, EE, HR, HU, LT, FI, LV, MD, RO, RS, SE, SI, SK, UA, AT, LU, NL, CH, BE, BY, NO, PL, DK; ^{**} Platinum only available in DE, EN, FR; ^{***} optional with Fendt Connect

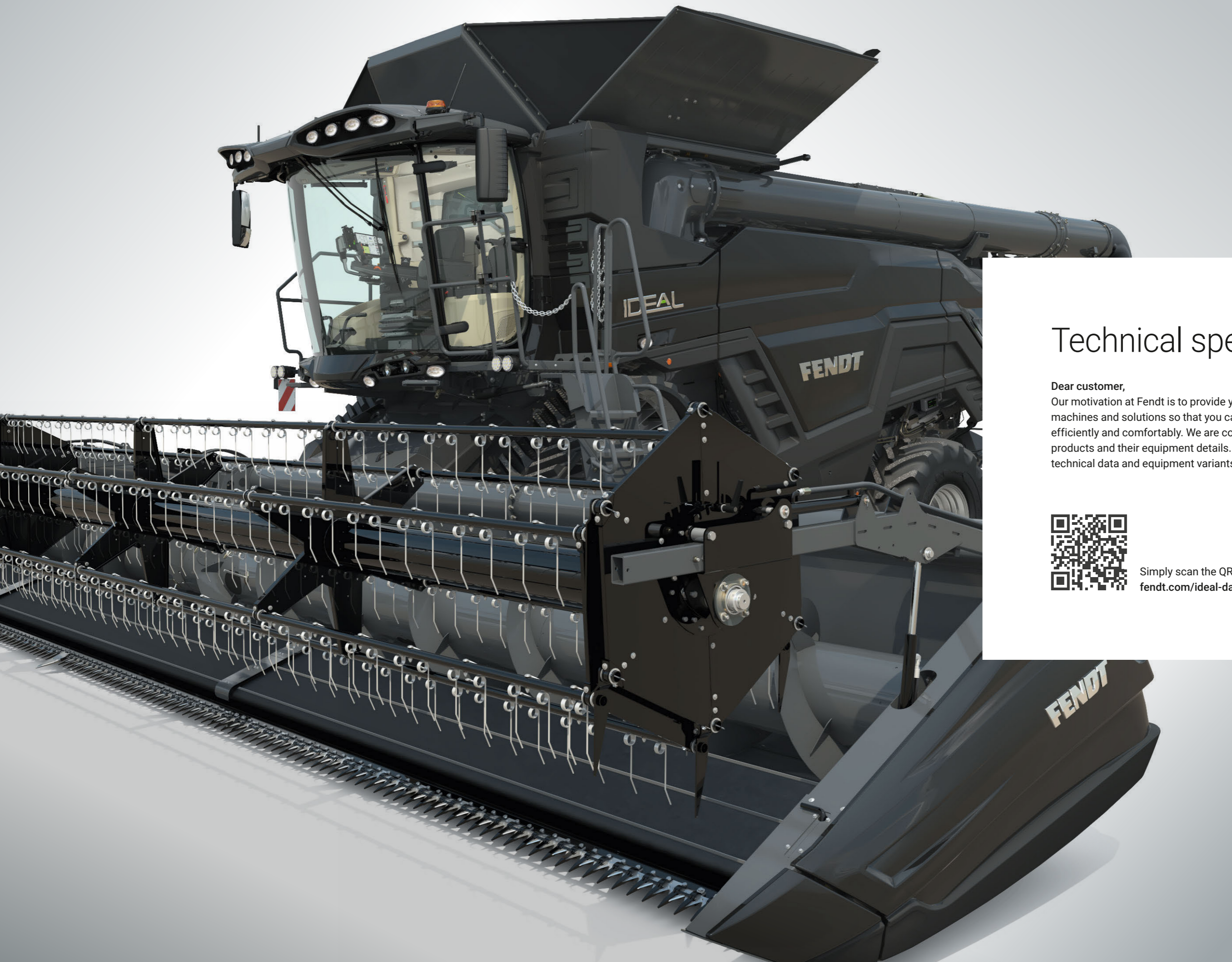

Technical specifications.

Dear customer,

Our motivation at Fendt is to provide you with the most innovative machines and solutions so that you can do your work even more efficiently and comfortably. We are constantly advancing our products and their equipment details. Therefore, you will find all technical data and equipment variants updated daily on our website.



Simply scan the QR code or follow the link below:
fendt.com/ideal-data

FENDT

Leaders drive Fendt.



www.fendt.com

AGCO GmbH – Fendt Marketing
87616 Marktoberdorf, Germany

EN/2401



Fendt is a worldwide brand of AGCO.

All details regarding scope of delivery, appearance, performance, dimensions and weights, fuel consumption and running costs of vehicles reflect the latest information available at the time of print. These may change by the time of purchase. Your Fendt dealer will be happy to inform you about any changes. The vehicles shown do not feature country-specific equipment.